

**Programmes After Market Services (P.A.M.S.)  
Technical Documentations  
NME-2A Series Transceivers**

# **Installation Instructions**

## Contents

	<b>Page No</b>
Introduction .....	5
Unpacking .....	6
Component Parts .....	7
Mounting Bracket MBE-2 .....	7
Handset Cradle CRE-1 .....	7
Mounting Plate MKE-1 and Swivel Mounting Plate HHS-1 .....	7
System Cable SCM-1/SCM-3 and Vehicle Installation cable DKS-3 .....	7
Handsfree Microphone HFM-14 and Handsfree Speaker HFS-10 ...	8
External Mobile Antenna (not supplied) .....	8
External SIM Card Reader .....	8
Installation .....	8
Power Distribution .....	10
Car Radio Muting (XCRM) .....	11
Ignition Sense (IGNS) .....	12
Power Antenna Control (ANTC) .....	12
Testing .....	13

## List of Figures

	<b>Page No</b>
Figure 1. Equipment Listing Diagram .....	6
Figure 2. Reducer .....	11
Figure 3. Connection – Radio Muting .....	12
Figure 4. Connection – Power Antenna Control .....	12

[This page intentionally left blank]

## Introduction

This installation guide has been prepared to provide the basic information necessary to install mobile phone. This guide is not intended to be definitive, because different types and models of vehicle will require different installation work. The information given is for general guidance only.

The terms of warranty demand that this mobile phone be installed by an experienced installation facility. An end user should never attempt to install this mobile phone without professional assistance as the installation requires special tools and knowledge.

Please refer to the phone's user guide for instructions on the phone's operation, care and maintenance, including important safety information.

Note: Read the warnings below before beginning the installation procedure.

### WARNINGS

1. **ENSURE THAT THE VEHICLE BATTERY IS DISCONNECTED BEFORE YOU START THE INSTALLATION PROCEDURE, AND THAT IT REMAINS DISCONNECTED DURING THE PROCEDURE.**
2. **DO NOT SMOKE OR USE OPEN FLAMES WHEN WORKING NEAR THE VEHICLE'S FUEL SYSTEM.**
3. **ENSURE THAT ELECTRICAL CABLES, HYDRAULIC LINES AND FUEL LINES ARE NOT DAMAGED DURING INSTALLATION.**
4. **ENSURE THAT NORMAL CONTROL AND OPERATION OF THE VEHICLE IS NOT IMPAIRED BY THE INSTALLATION, PARTICULARLY THE BRAKES AND STEERING.**
5. **ALTHOUGH ELECTRONIC SPEED CONTROL, ABS ANTI-LOCK BRAKE AND FUEL INJECTION SYSTEMS ARE RELATIVELY IMMUNE TO MALFUNCTION CAUSED BY NEARBY RADIO TRANSMISSIONS, SHOULD YOU EXPERIENCE FALSE OPERATION OF THESE SYSTEMS OR BE IN ANY DOUBT WHATSOEVER AS TO THEIR FUNCTIONALITY, PLEASE CONSULT THE VEHICLE DEALER.**
6. **THE MOBILE PHONE IS SUITABLE FOR USE ONLY IN VEHICLES WITH A 11..16 V NEGATIVE GROUNDING. USE ON OTHER SUPPLY VOLTAGES OR ALTERNATIVE POLARITY WILL DAMAGE THE EQUIPMENT.**
7. **THE PHONE SHOULD NOT BE LEFT SWITCHED ON FOR EXTENDED PERIODS WITHOUT RUNNING THE VEHICLE'S ENGINE. FAILURE TO COMPLY COULD DRAIN THE VEHICLE'S BATTERY.**

## Unpacking

Carefully unpack the equipment and ensure that the following items are present.

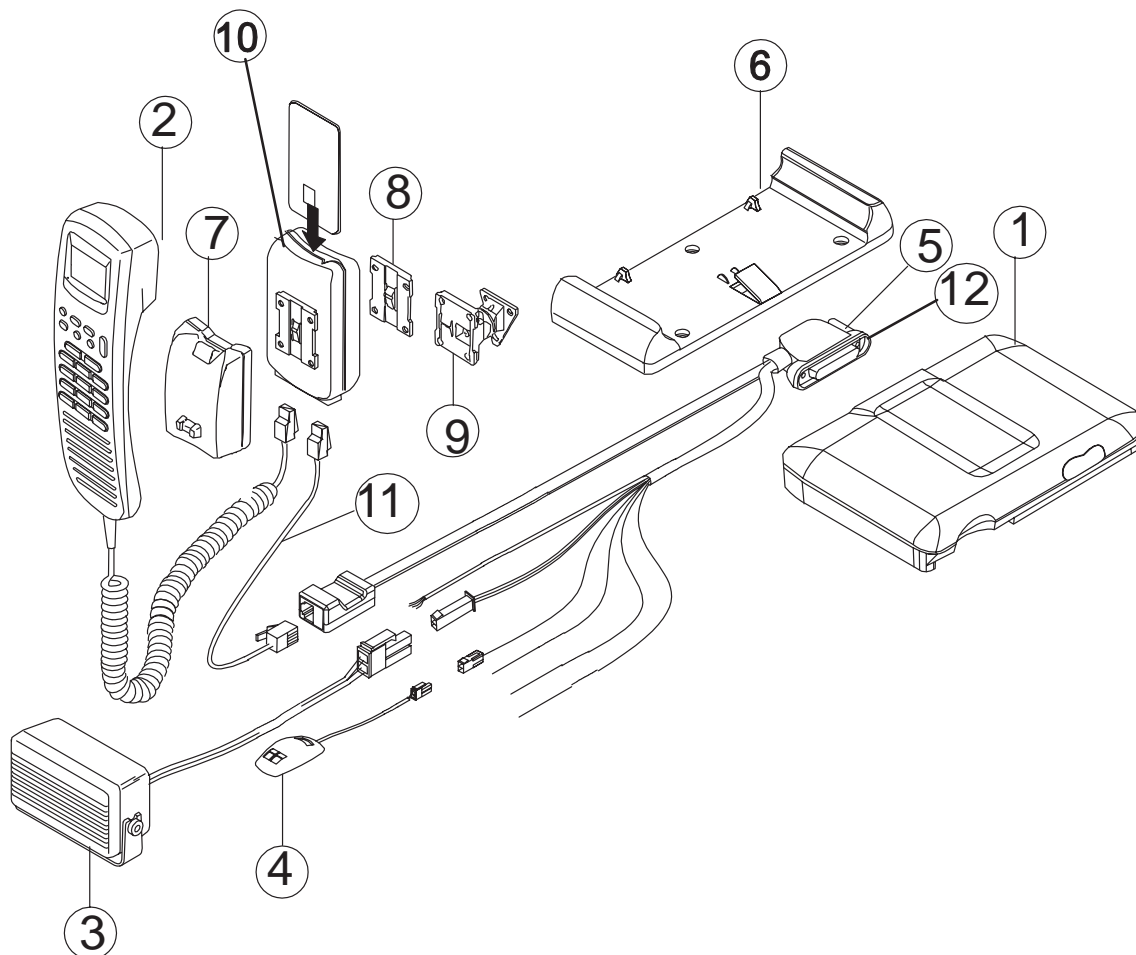

**Figure 1. Equipment listing diagram**

Item/Product Name:	Type:	Remarks:	Code:
1. Transceiver	NME-2A		0600088
2. Handset	HSE-6XA		0640086
3. Handsfree speaker	HFM-10	(Molex type conn)	0692006
4. Handsfree microphone	HFM-14	(Molex type conn)	0690014
5. System cable	SCM-1		0730066
6. Mounting bracket	MBE-2	(w/3 screws)	9450589
7. Handset cradle	CRE-1		0650001
8. Mounting plate	MKE-1	(w/12 screws)	0650007
9. Swivel mounting plate	HHS-1	(w/6 screws)	0650006
- Vehicle inst. cable	DKS-3	(not shown)	0730079
10 External SIM card reader	CAE-2		0630098
11 Extension cable SIM card	XCM-2		4624000
12 System cable (long)	SCM-3		0730107

## Component Parts

### Mounting Bracket MBE-2

The mounting bracket MBE-2 shall be installed using three screws. The bracket itself can to a certain degree compensate for unevenness of the mounting surface. However, should additional spacers be required, two different types are supplied with the bracket.

The transceiver may be installed in the bracket in two ways: either by sliding the transceiver into the bracket or by vertically inserting the transceiver from the top.

### Handset Cradle CRE-1

The cradle CRE-1 acts as a holder for the handset. The cradle is attached to the vehicle interior using mounting plate MKE-1 or swivel mount HHS-1.

### Mounting Plate MKE-1 and Swivel Mounting Plate HHS-1

MKE-1 is a fixed position mounting plate; HHS-1 is swivel mounting plate which allow adjustable fixing of the CRE-1 cradle. Both mounting plates are interchangeable.

### System Cable SCM-1/SCM-3 and Vehicle Installation Cable DKS-3

The system cable connects the phone to the vehicle supply and accessories. The long System Cable SCM-3 is optional.

The power wires red (+) and black (-) shall be routed to the battery itself (alternatively to the main distribution point of the vehicles fuse box) both + and - must be fuse protected (3 A).

The blue ignition sense (IGNS) wire is connected to +12 V voltage controlled by the vehicle's ignition key via the supplied fused connector. The ignition sense can utilize voltages up to 24 V, see section "Ignition Sense"

The yellow wire is used for car radio muting (XCRM). The line goes down to 0 volts during a call. The maximum sink current is 250 mA, hence the actual muting operation may have to be done using an auxiliary relay, or a muting unit provided by the manufacturer, see "Car Radio Muting".

The orange wire is used for motor antenna (ANTC). The voltage in this output is +12 V whenever the phone is on. The maximum sink current is 200 mA, so the actual motor antenna operation may have to be done by using an auxiliary relay, see "Power Antenna Control".

The RJ45 handset connector is performed by non-assembled. Locate the correct position, fasten the bottom shell with two screws, place the connector and cable and click the top on.

## Handsfree Microphone HFM-14 and Handsfree Speaker HFS-10

The safest and easiest way to have call while driving is use the handsfree option. The system consist of two components, the microphone HFM-14 and loudspeaker HFS-10.

The handsfree microphone can usually be installed on the drivers sunvisor or A-pillar. The main idea is to get the microphone as close to the drivers mouth as possible, and to attach the microphone to a surface that is mechanically quiet. The microphone connects to the system cable MIC molex connector.

The loudspeaker should be mounted at least 3 ft/1 m away from the handsfree microphone to avoid acoustic feedback. The loudspeaker connects to the system cable SPEAKER molex connector.

### External Mobile Antenna (not supplied)

The phone is designed to operate with a high quality external antenna. However, due to many different types of antennas being available, an antenna is NOT included as part of car kits. Please, consult the dealer to find out which is the most suitable antenna type for your installation.

### External SIM Card Reader

The CAE-2 is installed using a extension cable which is plugged into one of the modular connectors on the card reader and into the connector on the system cable normally used for the handset. The handset is then connected to the second modular connector on the card reader. After power up the system is ready for insertion of a SIM card. The SIM card is inserted with the arrow on the SIM card facing the light guide for the LED on the CAE-2. If the card is inserted upside down it will be rejected by the card reader, and the message CARD REJECTED is written in the display of the handset. If this happens, draw out the SIM card and insert it in the right way.

## Installation

There are some important aspects that require special attention in positioning mobile phone accessories.

The positioning of the handset holder is the most important factor when trying to achieve the most comfortable position for the user. The location of the holder should be selected so that the visibility of the handset's display is good under all lighting conditions, but not so that the driver's attention is easily distracted. The holder should be located so that the driver can easily reach the keypad. Under no circumstances should the holder prevent the driver from controlling or operating the vehicle in any way or observing traffic.



The phone mounting bracket may be installed in a variety of places including:

Ensure the location does not subject the phone to moisture or mechanical pressure or where there isn't adequate amount of air for cooling (under the carpet, etc.).

- . centre console below dash on either left or right side
- . any available shelf above or below dash
- . vacant DIN slot (consumes only half the height of a DIN slot)
- . under seats
- . trunk (with use of the SCM-3 system cable)

The handsfree microphone can be installed on the driver's sunvisor or the A-pillar. Ensure the microphone is as close to the driver's mouth as possible, and attached to a surface that is mechanically quiet. The microphone should be mounted at least 3 ft/1 m away from the handsfree unit speaker to avoid acoustic feedback. Ensure the microphone gain setting is in nokia position (default setting) with PCLocals or with handset by entering command xxxx and M.

The loudspeaker isn't so sensitive for vibrations, thus it can be located more freely. The main idea is to optimize two requirements: The driver should hear the signal from the loudspeaker without any special efforts, but attenuation between loudspeaker and microphone should be as high as possible, i.e. they must "look" in other directions in order to minimize the acoustic feedback.

Ensure cables are routed as far away as possible from the vehicle's electronic systems (refer to WARNINGS). Also ensure cables are not subjected to undue mechanical stress e.g. under seats or against sharp edges.

The most important component of the installation is the antenna. The location of the antenna as well the quality of the antenna and its installation have a considerable influence to the overall performance of the whole system. Therefore it is necessary to emphasize some aspects, which too often have caused unnecessary service work.

The best place for the antenna is the rooftop. The overall performance of a rooftop antenna is clearly superior to any other antenna type or location. The Antenna shall be mounted in a position such that no part of human body will normally rest too close to any part of the antenna unless there is an intervening metallic screen, for example, the metallic roof.

- highest place in the car
- proper ground place
- omni-directional radiation pattern
- minimum risk for disturbances
- user safety

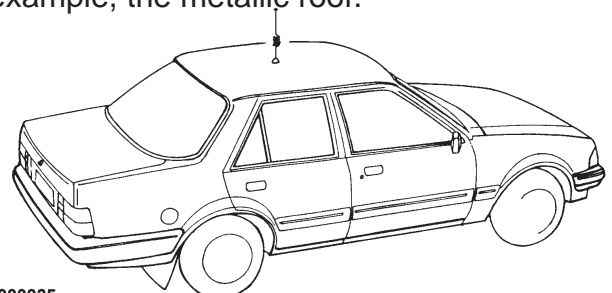

S0000035

After drilling the hole for the antenna remember to clean the hole from the drilling swarf, so that surface is even. This is needed in order to ensure proper and reliable connection between the ground plane and the antenna. After cleaning it is advised to apply some rust-proofing compound to the hole.

Mount the base of the antenna tightly in position. Consult the antennas manual for determining the maximum bending angle before attempting any bending operation.

To avoid drilling a hole in the vehicle's bodywork, a glass-mounted antenna can be chosen and located on the rear window of the vehicle.

Try to route the antenna cable so that possible sources of disturbances are avoided, as well anti-skid brake systems. The shorter the antenna cable, the smaller the attenuation, and the better the performance of the antenna. The antenna coupler should always be connected to the antenna via a non-radiating cable (e.g. coax).

Most of the antennas today have adapted the mini-crimp connector system which eliminates the need for special crimping tools and connectors. If however the purchased antenna has traditional connectors, use only proper connectors and tools. The phone uses mini a UHF female type antenna connector for reasons of reliability and attenuation.

All installations should take into account any special requirements of the customer. However, should the customer require an installation that is illegal or unsafe these facts must be pointed out to the customer and a policy of non-compliance adopted.

## Power Distribution

The main supply for mobile phone is obtained from the vehicle battery, the supply voltage may vary between 11 and 16 volts. Both the positive voltage and the grounding are taken directly from the battery, unless the vehicle has other main voltage than +12 V. This minimizes the risk of disturbances from or to the telephone as well as guarantees loss-free power distribution.

The connections to the battery should be carried out with care. Both the negative and positive leads have 3A fuses, which must always be used. If a fuse blows, replace it only with the same type and size fuse.

The power cables should be routed so that possible sources of disturbances are avoided. Also ABS-sensors and like should be avoided as far as possible.

If the vehicle has +24 V electrical system (trucks, all-terrain vehicles , etc.), an external voltage reducer must be used. Since the properties of the reducer are critical, it is recommended to use a reducer supplied by the manufacturer. This reducer has good protections against transients produced by vehicles electrical system and it is also capable of maintaining stable output during rapid changes in load current.

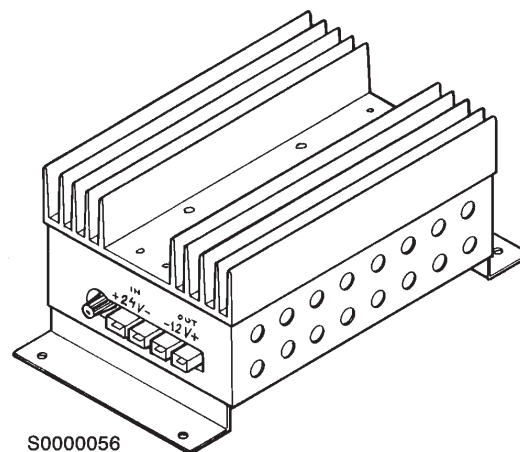

**Figure 2. Reducer**

Some vehicles have a main switch (e.g. gas trucks), which separates the vehicles chassis from the negative lead of the battery. Do under no circumstances pass this switch, i.e. the grounding of the reducer must be taken from the body of the vehicle, NOT directly from the battery.

**WARNING : DO NOT INSTALL REDUCER**

- To engine compartment
- Where there isn't adequate amount of air for cooling (under the carpet, etc.)
- Where there is risk of moisture (condensed water, etc.)

### Car Radio Muting (XCRM)

The phone offers a feature that can mute the car radio automatically during a conversation. This feature is convenient and provides for safer handsfree operation. The car radio muting feature based on grounded line, so it means that in standby, the yellow wire (XCRM) is not grounded and car radio works normally, but during a call, line is grounded and car radio is muted. The maximum load that this line can handle is 250 mA. Note that an auxiliary relay or muting unit must be used when the car radio doesn't have a mute feature available.

When a relay is used, connect of series with the car radio main supply. A 200 mA fuse should be used to protect the XCRM output in event of a short circuit. Some radios have separate supplies for amplifiers and motors, and another for memory backup purposes. Very often these radios also have a secret code system, which activates itself if a break in the memory supply is detected. Be careful when installing the relay not to break the memory supply (usually marked ACC or +MEM), but to install the relay in the main supply feed.

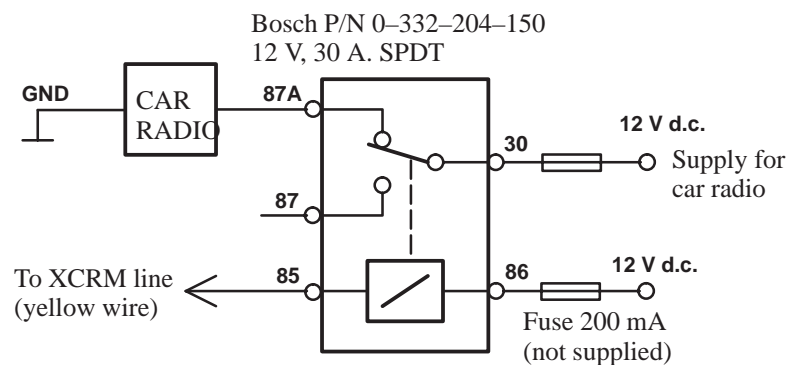

**Figure 3. Connection – Radio Muting**

Another possibility is to use a special muting unit (SR59), which mutes the radio by connecting load resistors to the speaker lines of the car radio. Four loudspeakers can be muted and the maximum permitted power is 20 watts per channel. The muting unit can also be used as a relay to cut the main supply feed of the car radio.

## Ignition Sense (IGNS)

The ignition sense feature prevents the transceiver from draining the car battery by executing an auto power off 3 minutes after the ignition key has been turned off (unless the Auto Power Off feature is activated).

The blue wire of the power cable is used for the ignition sense feature. The use of IGNITION SENSE is recommended to prevent accidental draining of the car's battery. The wire is connected via a 200 mA fuse to a 12/24 volts potential that is controlled by the ignition key. Do not connect it directly to the high voltage sections of the ignition circuit. If the feature is not used, just leave the wire unconnected, and protect the end of the cable with insulating tape.

## Power Antenna Control (ANTC)

The orange wire of the system cable (ANTC) may be used to control different devices on and off. The voltage in this output is +12 V whenever the phone is on. If the phone is turned off, the voltage disappears. The maximum output current is 200 mA, therefore for example motorized antenna must be controlled via a relay, see picture below.

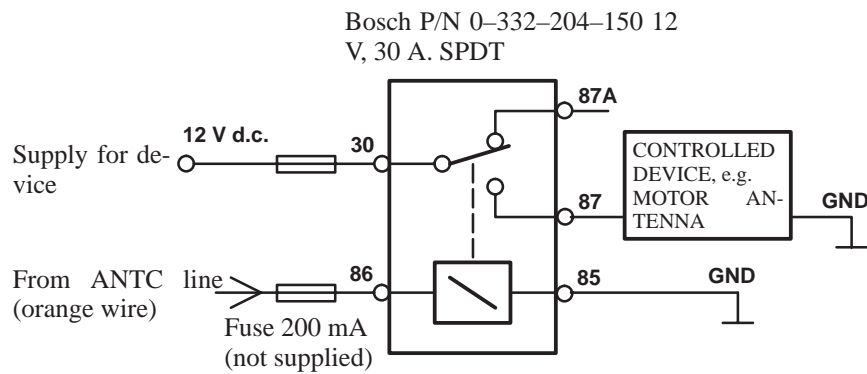

**Figure 4. Connection – Power Antenna Control**

## Testing

Once installed, the equipment should be tested to ensure that it is operating satisfactorily and that the position of the units does not impair on the driver's ability to control and operate the vehicle in any way.

Use the phone to make a call when the vehicle is parked with the engine running. During the call, switch off the engine. Ensure that the phone is operational with the engine running and with the engine switched off. For operating information refer to the 'User Guide' supplied with the phone.

[This page intentionally left blank]